



Institut für Elektrische Energiesysteme, htw saar

Lastflussberechnung

27.03.2026, 11:17:46.315

C:\ATPDesigner\00_7_1_ATPDesManualNetze\Netz20kVMittelspannung.bnet

ATPDesigner Version 4.02.12 - 14.03.2026

Version NET File 6.3 - 22.01.2021



Bezeichner und Erläuterungen

n	Nennwert, z.B. Nennspannung U_n
r	Bemessungswert, z.B. Bemessungsstrom I_r
UL1, UL2, UL3 [V], [%]	Betrag der Leiter-Erd-Spannungen in V und $\%U_n/\sqrt{3}$
U12, U23, U31 [V], [%]	Betrag der Leiter-Leiter-Spannungen in V und $\%U_n$
Umin, Umax [V], [%]	Betrag der kleinsten und größten Leiter-Erd- und Leiter-Leiter-Spannung UL123 in V und $\%U_n$
ULL, ULE [V], [%]	Betrag der Leiter-Leiter-Spannungen U12, U23 und U31 in V und $\%U_n$ Betrag der Leiter-Erd-Spannungen UL1, UL2 und UL3 in V und $\%U_n/\sqrt{3}$
IL1, IL2, IL3 [A], [%]	Betrag der Leiterströme in A und $\%I_n$
U1, U2, U0 [V], [%]	Betrag der Mitsystem-, Gegensystem- und Nullsystemspannung in V und $\%U_n/\sqrt{3}$
I1, I2, I0 [A], [%]	Betrag des Mitsystem-, Gegensystem- und Nullsystemstroms in A und $\%I_n$
ILmax [A], [%]	Betrag des größten der Leiterströme IL123 in A und $\%I_n = I_{max} \cdot Red.$
Auslastung [%In]	Betrag des maximalen Leiterstroms IL123 in $\%I_n$
Auslastung Smax, Smin [%Sr]	Betrag der maximalen oder minimalen Scheinleistung S in $\%S_r$
S [VA]	Betrag der Scheinleistung in VA
P [W]	Betrag der Wirkleistung in W
Q [var]	Betrag der Blindleistung in var
ULEn	$ULE_n = U_n/\sqrt{3}$
max	maximal
min	minimal
CosPhi	Verschiebungsfaktor $\cos \phi = P / S$
Auslastung [%]	Auslastung der Windungen A und B in $\%I_n$
SL1, SL2, SL3 [VA]	Einphasige Scheinleistung der drei Leiter L1, L2, L3 in VA
PL1, PL2, PL3 [W]	Einphasige Wirkleistung der drei Leiter L1, L2, L3 in W
QL1, QL2, QL3 [var]	Einphasige Blindleistung der drei Leiter L1, L2, L3 in var
HB	Handlungsbedarf
ILmax [%]	Maximaler Leiterstrom IL123 in $\%I_n$
fN [%]	Netzfaktor (Grid Health) in %
m [p.u.]	Belastungsgrad nach VDE 0276
LF	Status Lastflussberechnung: Konvergenz=1, Divergenz=0, Abbruch=2, ungültig=-1
TRIP	Netzschutz: AUS-Kommando - 0=gehend, 1=kommend
GEN	Netzschutz: Generalanregung - 0=gehend, 1=kommend
DSZ	Netzschutz: Distanzzone des Distanzschutzes mit AUS-Kommando
R1k	Netzschutz: Resistanz der Kurzschlussimpedanz im Mitsystem
X1k	Netzschutz: Reaktanz der Kurzschlussimpedanz im Mitsystem
DST	Daylight Saving Time: Sommerzeit = S, Winterzeit = W
Zustand	Gesamtergebnis für das Betriebsmittel nach BDEW-Ampelmodell (Grün, Gelb, Rot)
Aktiviert (Akt) Deaktiviert (Deakt)	Netzwerkelement: aktiviert (Akt) oder deaktiviert (Deakt)

Topologie des Stromnetzes

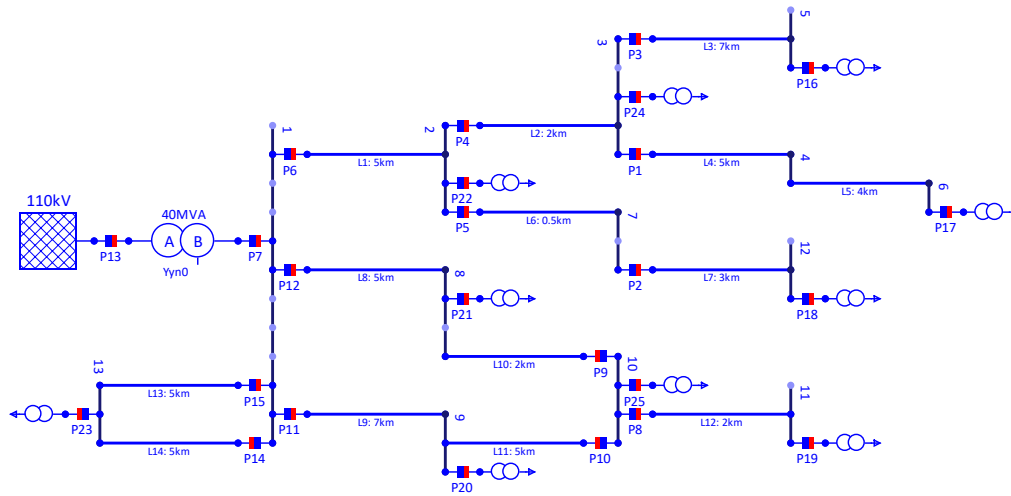

Kurzschluss

Kurzschluss	---
Betriebsmittel	---
Kurzschlussknoten	---
I _{kL1} ; phi	---
I _{kL2} ; phi	---
I _{kL3} ; phi	---

Zusammenfassung

Name	Netzzustand
Stromnetz	Grün
Sammelschiene: [Bb 1] 1	Grün
Sammelschiene: [Bb 2] 2	Grün
Sammelschiene: [Bb 3] 3	Grün
Sammelschiene: [Bb 4] 7	Grün
Sammelschiene: [Bb 5] 5	Grün
Sammelschiene: [Bb 6] 4	Grün
Sammelschiene: [Bb 7] 6	Grün
Sammelschiene: [Bb 8] 12	Grün
Sammelschiene: [Bb 9] 8	Grün
Sammelschiene: [Bb 10] 9	Grün
Sammelschiene: [Bb 11] 11	Grün
Sammelschiene: [Bb 12] 10	Grün
Sammelschiene: [Bb 13] 13	Grün
Transformator 2-Wicklung: [Tra 1] 40MVA	Grün
Transformator 2-Wicklung: [Tra 2] Tra 2	Grün
Transformator 2-Wicklung: [Tra 3] Tra 3	Grün
Transformator 2-Wicklung: [Tra 4] Tra 4	Grün
Transformator 2-Wicklung: [Tra 5] Tra 5	Grün
Transformator 2-Wicklung: [Tra 6] Tra 6	Grün
Transformator 2-Wicklung: [Tra 7] Tra 7	Grün
Transformator 2-Wicklung: [Tra 8] Tra 8	Grün
Transformator 2-Wicklung: [Tra 9] Tra 9	Grün
Transformator 2-Wicklung: [Tra 10] Tra 10	Grün
Transformator 2-Wicklung: [Tra 11] Tra 11	Grün
Mess/Schutzgerät: [Prb 1] P1	Grün
Mess/Schutzgerät: [Prb 2] P2	Grün
Mess/Schutzgerät: [Prb 3] P3	Grün
Mess/Schutzgerät: [Prb 4] P4	Grün
Mess/Schutzgerät: [Prb 5] P5	Grün
Mess/Schutzgerät: [Prb 6] P6	Grün
Mess/Schutzgerät: [Prb 7] P7	Grün
Mess/Schutzgerät: [Prb 8] P8	Grün
Mess/Schutzgerät: [Prb 9] P9	Grün
Mess/Schutzgerät: [Prb 11] P11	Grün
Mess/Schutzgerät: [Prb 12] P12	Grün
Mess/Schutzgerät: [Prb 10] P10	Grün
Mess/Schutzgerät: [Prb 13] P13	Grün
Mess/Schutzgerät: [Prb 14] P14	Grün
Mess/Schutzgerät: [Prb 15] P15	Grün
Mess/Schutzgerät: [Prb 16] P16	Grün
Mess/Schutzgerät: [Prb 17] P17	Grün
Mess/Schutzgerät: [Prb 18] P18	Grün
Mess/Schutzgerät: [Prb 19] P19	Grün
Mess/Schutzgerät: [Prb 20] P20	Grün
Mess/Schutzgerät: [Prb 21] P21	Grün
Mess/Schutzgerät: [Prb 22] P22	Grün
Mess/Schutzgerät: [Prb 23] P23	Grün
Mess/Schutzgerät: [Prb 24] P24	Grün
Mess/Schutzgerät: [Prb 25] P25	Grün
Leitung: [Line 4] L1: 5km	Grün
Leitung: [Line 5] L2: 2km	Grün
Leitung: [Line 6] L6: 0.5km	Grün
Leitung: [Line 7] L3: 7km	Grün
Leitung: [Line 8] L4: 5km	Grün

Leitung: [Line 9] L5: 4km	Grün
Leitung: [Line 10] L8: 5km	Grün
Leitung: [Line 11] L7: 3km	Grün
Leitung: [Line 12] L10: 2km	Grün
Leitung: [Line 13] L9: 7km	Grün
Leitung: [Line 14] L11: 5km	Grün
Leitung: [Line 15] L12: 2km	Grün
Leitung: [Line 16] L14: 5km	Grün
Leitung: [Line 17] L13: 5km	Grün
Netzeinspeisung: [Network 1] 110kV	Grün

Spannungsüberwachung: Sammelschiene

Name	Un [kV]	U12 [%]	U23 [%]	U31 [%]	U<> [%]	HB [%]	Zustand
[Bb 1] 1	20	100.81	100.81	100.81	90% - 110%	0	Grün
[Bb 2] 2	20	100.73	100.73	100.73	90% - 110%	0	Grün
[Bb 3] 3	20	100.71	100.71	100.71	90% - 110%	0	Grün
[Bb 4] 7	20	100.72	100.72	100.72	90% - 110%	0	Grün
[Bb 5] 5	20	100.68	100.68	100.68	90% - 110%	0	Grün
[Bb 6] 4	20	100.70	100.70	100.70	90% - 110%	0	Grün
[Bb 7] 6	20	100.68	100.68	100.68	90% - 110%	0	Grün
[Bb 8] 12	20	100.70	100.70	100.70	90% - 110%	0	Grün
[Bb 9] 8	20	100.76	100.76	100.76	90% - 110%	0	Grün
[Bb 10] 9	20	100.77	100.77	100.77	90% - 110%	0	Grün
[Bb 11] 11	20	100.73	100.73	100.73	90% - 110%	0	Grün
[Bb 12] 10	20	100.74	100.74	100.74	90% - 110%	0	Grün
[Bb 13] 13	20	100.81	100.81	100.81	90% - 110%	0	Grün

Name	Un [kV]	UL1 [%]	UL2 [%]	UL3 [%]	U<> [%]	HB [%]	Zustand
[Bb 1] 1	20	100.81	100.81	100.81	90% - 110%	0	Grün
[Bb 2] 2	20	100.73	100.73	100.73	90% - 110%	0	Grün
[Bb 3] 3	20	100.71	100.71	100.71	90% - 110%	0	Grün
[Bb 4] 7	20	100.72	100.72	100.72	90% - 110%	0	Grün
[Bb 5] 5	20	100.68	100.68	100.68	90% - 110%	0	Grün
[Bb 6] 4	20	100.70	100.70	100.70	90% - 110%	0	Grün
[Bb 7] 6	20	100.68	100.68	100.68	90% - 110%	0	Grün
[Bb 8] 12	20	100.70	100.70	100.70	90% - 110%	0	Grün
[Bb 9] 8	20	100.76	100.76	100.76	90% - 110%	0	Grün
[Bb 10] 9	20	100.77	100.77	100.77	90% - 110%	0	Grün
[Bb 11] 11	20	100.73	100.73	100.73	90% - 110%	0	Grün
[Bb 12] 10	20	100.74	100.74	100.74	90% - 110%	0	Grün
[Bb 13] 13	20	100.81	100.81	100.81	90% - 110%	0	Grün

Name	Un [kV]	U1 [%]	U2 [%]	U0 [%]	phiU1 [°]	phiU2 [°]	phiU0 [°]	Zustand
[Bb 1] 1	20	100.81	0.00	0.00	-91.49	-85.66	-102.78	Grün
[Bb 2] 2	20	100.73	0.00	0.00	-91.72	-95.55	-102.45	Grün
[Bb 3] 3	20	100.71	0.00	0.00	-91.78	-95.92	-102.40	Grün
[Bb 4] 7	20	100.72	0.00	0.00	-91.73	-95.92	-102.45	Grün
[Bb 5] 5	20	100.68	0.00	0.00	-91.84	-94.16	-102.50	Grün
[Bb 6] 4	20	100.70	0.00	0.00	-91.83	-95.36	-102.43	Grün
[Bb 7] 6	20	100.68	0.00	0.00	-91.86	-95.14	-102.39	Grün
[Bb 8] 12	20	100.70	0.00	0.00	-91.75	-96.80	-102.42	Grün
[Bb 9] 8	20	100.76	0.00	0.00	-91.59	-87.60	-102.83	Grün
[Bb 10] 9	20	100.77	0.00	0.00	-91.59	-87.19	-102.88	Grün
[Bb 11] 11	20	100.73	0.00	0.00	-91.63	-88.17	-102.80	Grün
[Bb 12] 10	20	100.74	0.00	0.00	-91.62	-89.63	-102.84	Grün

[Bb 13] 13	20	100.81	0.00	0.00	-91.51	-85.44	-102.83	Grün
------------	----	--------	------	------	--------	--------	---------	------

Häufigkeiten der Sammelschienenspannungen

Klassen	ULL	ULE	U1
<=90%	0	0	0
]90% - 92%]	0	0	0
]92% - 94%]	0	0	0
]94% - 96%]	0	0	0
]96% - 98%]	0	0	0
]98% - 100%]	0	0	0
]100% - 102%]	13	13	13
]102% - 104%]	0	0	0
]104% - 106%]	0	0	0
]106% - 108%]	0	0	0
]108% - 110%]	0	0	0
>110%	0	0	0

Leistungsbezug: Transformator 2-Wicklung - Interne Verbraucherlast

Name	Sr [MVA]	S [MVA]	P [MW]	Q [Mvar]	CosPhi
[Tra 2] Tra 2, Load 100001	0.500000	0.502172	0.502172	-0.000000	1.000
[Tra 3] Tra 3, Load 100003	0.500000	0.501917	0.501917	-0.000000	1.000
[Tra 4] Tra 4, Load 100004	0.500000	0.501916	0.501916	-0.000000	1.000
[Tra 5] Tra 5, Load 100005	0.500000	0.502419	0.502419	-0.000000	1.000
[Tra 6] Tra 6, Load 100006	0.500000	0.502573	0.502573	-0.000000	1.000
[Tra 7] Tra 7, Load 100007	0.500000	0.503214	0.503214	-0.000000	1.000
[Tra 8] Tra 8, Load 100008	0.500000	0.502708	0.502708	-0.000000	1.000
[Tra 9] Tra 9, Load 100009	0.500000	0.502810	0.502810	-0.000000	1.000
[Tra 10] Tra 10, Load 100010	0.500000	0.502412	0.502412	-0.000000	1.000
[Tra 11] Tra 11, Load 100011	0.500000	0.502260	0.502260	-0.000000	1.000

Leistungsbezug: Leitung - Interne Verbraucherlast

Name	Sr [MVA]	S [MVA]	P [MW]	Q [Mvar]	CosPhi
------	----------	---------	--------	----------	--------

Spannungsüberwachung: Mess/Schutzgerät

Name	Un [kV]	U12 [%]	U23 [%]	U31 [%]	Zustand
[Prb 1] P1	20	100.711	100.711	100.711	Grün
[Prb 2] P2	20	100.723	100.723	100.723	Grün
[Prb 3] P3	20	100.711	100.711	100.711	Grün
[Prb 4] P4	20	100.726	100.726	100.726	Grün
[Prb 5] P5	20	100.726	100.726	100.726	Grün
[Prb 6] P6	20	100.814	100.814	100.814	Grün
[Prb 7] P7	20	100.814	100.814	100.814	Grün
[Prb 8] P8	20	100.742	100.742	100.742	Grün
[Prb 9] P9	20	100.742	100.742	100.742	Grün
[Prb 11] P11	20	100.814	100.814	100.814	Grün
[Prb 12] P12	20	100.814	100.814	100.814	Grün
[Prb 10] P10	20	100.742	100.742	100.742	Grün
[Prb 13] P13	110	100.27	100.27	100.27	Grün
[Prb 14] P14	20	100.814	100.814	100.814	Grün
[Prb 15] P15	20	100.814	100.814	100.814	Grün
[Prb 16] P16	20	100.676	100.676	100.676	Grün

[Prb 17] P17	20	100.676	100.676	100.676	Grün
[Prb 18] P18	20	100.702	100.702	100.702	Grün
[Prb 19] P19	20	100.727	100.727	100.727	Grün
[Prb 20] P20	20	100.766	100.766	100.766	Grün
[Prb 21] P21	20	100.756	100.756	100.756	Grün
[Prb 22] P22	20	100.726	100.726	100.726	Grün
[Prb 23] P23	20	100.806	100.806	100.806	Grün
[Prb 24] P24	20	100.711	100.711	100.711	Grün
[Prb 25] P25	20	100.742	100.742	100.742	Grün

Name	Un [kV]	UL1 [%]	UL2 [%]	UL3 [%]	Zustand
[Prb 1] P1	20	100.711	100.711	100.711	Grün
[Prb 2] P2	20	100.724	100.723	100.723	Grün
[Prb 3] P3	20	100.711	100.711	100.711	Grün
[Prb 4] P4	20	100.726	100.726	100.726	Grün
[Prb 5] P5	20	100.726	100.726	100.726	Grün
[Prb 6] P6	20	100.815	100.814	100.814	Grün
[Prb 7] P7	20	100.815	100.814	100.814	Grün
[Prb 8] P8	20	100.742	100.742	100.742	Grün
[Prb 9] P9	20	100.742	100.742	100.742	Grün
[Prb 11] P11	20	100.815	100.814	100.814	Grün
[Prb 12] P12	20	100.815	100.814	100.814	Grün
[Prb 10] P10	20	100.742	100.742	100.742	Grün
[Prb 13] P13	110	100.27	100.27	100.27	Grün
[Prb 14] P14	20	100.815	100.814	100.814	Grün
[Prb 15] P15	20	100.815	100.814	100.814	Grün
[Prb 16] P16	20	100.676	100.676	100.676	Grün
[Prb 17] P17	20	100.677	100.676	100.676	Grün
[Prb 18] P18	20	100.702	100.702	100.702	Grün
[Prb 19] P19	20	100.727	100.727	100.726	Grün
[Prb 20] P20	20	100.766	100.766	100.766	Grün
[Prb 21] P21	20	100.756	100.756	100.755	Grün
[Prb 22] P22	20	100.726	100.726	100.726	Grün
[Prb 23] P23	20	100.807	100.806	100.806	Grün
[Prb 24] P24	20	100.711	100.711	100.711	Grün
[Prb 25] P25	20	100.742	100.742	100.742	Grün

Leiterstromüberwachung: Mess/Schutzgerät

Name	Ir [A]	IL1 [%]	IL1 [A]	IL2 [%]	IL2 [A]	IL3 [%]	IL3 [A]	Zustand
[Prb 1] P1	630	2.77	17.47	2.77	17.47	2.77	17.47	Grün
[Prb 2] P2	630	2.34	14.74	2.34	14.74	2.34	14.74	Grün
[Prb 3] P3	630	2.58	16.28	2.58	16.28	2.58	16.28	Grün
[Prb 4] P4	630	7.51	47.34	7.51	47.34	7.51	47.34	Grün
[Prb 5] P5	630	2.36	14.86	2.36	14.86	2.36	14.86	Grün
[Prb 6] P6	630	12.28	77.36	12.28	77.36	12.28	77.36	Grün
[Prb 7] P7	630	24.87	156.69	24.87	156.69	24.87	156.69	Grün
[Prb 8] P8	630	2.31	14.57	2.31	14.57	2.31	14.57	Grün
[Prb 9] P9	630	3.19	20.10	3.19	20.10	3.19	20.10	Grün
[Prb 11] P11	630	4.12	25.97	4.12	25.97	4.12	25.97	Grün
[Prb 12] P12	630	5.71	35.97	5.71	35.97	5.71	35.97	Grün
[Prb 10] P10	630	1.51	9.48	1.51	9.48	1.51	9.48	Grün
[Prb 13] P13	630	4.51	28.40	4.51	28.40	4.51	28.40	Grün
[Prb 14] P14	630	1.44	9.09	1.44	9.09	1.44	9.09	Grün
[Prb 15] P15	630	1.44	9.09	1.44	9.09	1.44	9.09	Grün
[Prb 16] P16	630	2.30	14.49	2.30	14.49	2.30	14.49	Grün
[Prb 17] P17	630	2.30	14.49	2.30	14.49	2.30	14.49	Grün
[Prb 18] P18	630	2.30	14.49	2.30	14.49	2.30	14.49	Grün

[Prb 19] P19	630	2.30	14.49	2.30	14.49	2.30	14.49	Grün
[Prb 20] P20	630	2.30	14.50	2.30	14.50	2.30	14.50	Grün
[Prb 21] P21	630	2.30	14.50	2.30	14.50	2.30	14.50	Grün
[Prb 22] P22	630	2.30	14.49	2.30	14.49	2.30	14.49	Grün
[Prb 23] P23	630	2.30	14.51	2.30	14.51	2.30	14.51	Grün
[Prb 24] P24	630	2.30	14.49	2.30	14.49	2.30	14.49	Grün
[Prb 25] P25	630	2.30	14.50	2.30	14.50	2.30	14.50	Grün

Verlustleistung

Anzahl 2-Wicklungs-Transformatoren	11
Anzahl Leitungen	14
Anzahl 2/3-Wicklungs-Transformatoren (BCTAN)	0

Name	S [kVA]	P [kW]	Q [kvar]	CosPhi
[Tra 1] 40MVA	185.444	20.9255	184.26	0.11284
[Tra 2] Tra 2	25.1535	2.68824	25.0095	0.106873
[Tra 3] Tra 3	25.1408	2.68687	24.9968	0.106873
[Tra 4] Tra 4	25.1407	2.68687	24.9967	0.106873
[Tra 5] Tra 5	25.1659	2.68956	25.0218	0.106873
[Tra 6] Tra 6	25.1736	2.69039	25.0294	0.106873
[Tra 7] Tra 7	25.2057	2.69382	25.0614	0.106873
[Tra 8] Tra 8	25.1804	2.69111	25.0362	0.106873
[Tra 9] Tra 9	25.1855	2.69166	25.0413	0.106873
[Tra 10] Tra 10	25.1656	2.68953	25.0214	0.106873
[Tra 11] Tra 11	25.158	2.68871	25.0139	0.106873
[Line 4] L1: 5km	194.627	5.68925	-194.543	0.0292316
[Line 5] L2: 2km	80.1382	0.857351	-80.1336	0.0106984
[Line 6] L6: 0.5km	20.3626	0.0213473	-20.3626	0.00104836
[Line 7] L3: 7km	284.895	0.301307	-284.895	0.00105761
[Line 8] L4: 5km	203.491	0.250205	-203.491	0.00122957
[Line 9] L5: 4km	162.796	0.16535	-162.796	0.00101569
[Line 10] L8: 5km	202.19	1.20841	-202.186	0.00597662
[Line 11] L7: 3km	122.154	0.123165	-122.154	0.00100827
[Line 12] L10: 2km	81.3611	0.161286	-81.3609	0.00198235
[Line 13] L9: 7km	284.561	0.823251	-284.56	0.00289306
[Line 14] L11: 5km	203.967	0.0816775	-203.967	0.000400444
[Line 15] L12: 2km	81.472	0.0818115	-81.4719	0.00100417
[Line 16] L14: 5km	204.237	0.0575865	-204.237	0.00028196
[Line 17] L13: 5km	204.237	0.0575865	-204.237	0.00028196
Sum	2767.6	57.7018	-1895.91	0.020849

Ergebnisse Lastflussberechnung: Leitung

Name	IL1 [A]	IL2 [A]	IL3 [A]	ILmax [A]	ILmax [%]	I1 [A]	I2 [A]	I0 [A]	Zustand
[Line 4] L1: 5km	77.36	77.36	77.36	77.36	12.91	77.36	0.00	0.00	Grün
[Line 5] L2: 2km	47.34	47.34	47.34	47.34	7.90	47.34	0.00	0.00	Grün
[Line 6] L6: 0.5km	14.86	14.86	14.86	14.86	2.48	14.86	0.00	0.00	Grün
[Line 7] L3: 7km	16.28	16.28	16.28	16.28	2.72	16.28	0.00	0.00	Grün
[Line 8] L4: 5km	17.47	17.47	17.47	17.47	2.92	17.47	0.00	0.00	Grün
[Line 9] L5: 4km	15.00	15.00	15.00	15.00	2.50	15.00	0.00	0.00	Grün
[Line 10] L8: 5km	35.97	35.97	35.97	35.97	6.01	35.97	0.00	0.00	Grün
[Line 11] L7: 3km	14.74	14.74	14.74	14.74	2.46	14.74	0.00	0.00	Grün
[Line 12] L10: 2km	20.63	20.63	20.63	20.63	3.44	20.63	0.00	0.00	Grün
[Line 13] L9: 7km	25.97	25.97	25.97	25.97	4.34	25.97	0.00	0.00	Grün
[Line 14] L11: 5km	9.73	9.73	9.73	9.73	1.62	9.73	0.00	0.00	Grün
[Line 15] L12: 2km	14.57	14.57	14.57	14.57	2.43	14.57	0.00	0.00	Grün

[Line 16] L14: 5km	9.09	9.09	9.09	9.09	1.52	9.09	0.00	0.00	Grün
[Line 17] L13: 5km	9.09	9.09	9.09	9.09	1.52	9.09	0.00	0.00	Grün

Name	Un [kV]	ULEmin [%]	ULEmax [%]	Zustand
[Line 4] L1: 5km	20.0	100.73	100.81	Grün
[Line 5] L2: 2km	20.0	100.71	100.73	Grün
[Line 6] L6: 0.5km	20.0	100.72	100.73	Grün
[Line 7] L3: 7km	20.0	100.68	100.71	Grün
[Line 8] L4: 5km	20.0	100.70	100.71	Grün
[Line 9] L5: 4km	20.0	100.68	100.70	Grün
[Line 10] L8: 5km	20.0	100.76	100.81	Grün
[Line 11] L7: 3km	20.0	100.70	100.72	Grün
[Line 12] L10: 2km	20.0	100.74	100.76	Grün
[Line 13] L9: 7km	20.0	100.77	100.81	Grün
[Line 14] L11: 5km	20.0	100.74	100.77	Grün
[Line 15] L12: 2km	20.0	100.73	100.74	Grün
[Line 16] L14: 5km	20.0	100.81	100.81	Grün
[Line 17] L13: 5km	20.0	100.81	100.81	Grün

Ergebnisse Lastflussberechnung: Transformator 2-Wicklung

Name	S [kVA]	S [%Sr]	P [kW]	Q [kvar]	Umax [%]	Umin [%]	ILmax(A) [%]	ILmax(B) [%]	Zustand
[Tra 1] 40MVA	5424.44	13.56	5082.33	-1895.91	100.81	100.27	13.52	13.52	Grün
[Tra 2] Tra 2	505.48	50.55	504.86	25.01	100.70	100.22	28.98	50.20	Grün
[Tra 3] Tra 3	505.22	50.52	504.60	25.00	100.68	100.19	28.97	50.18	Grün
[Tra 4] Tra 4	505.22	50.52	504.60	25.00	100.68	100.19	28.97	50.18	Grün
[Tra 5] Tra 5	505.73	50.57	505.11	25.02	100.73	100.24	28.99	50.21	Grün
[Tra 6] Tra 6	505.88	50.59	505.26	25.03	100.74	100.26	28.99	50.22	Grün
[Tra 7] Tra 7	506.53	50.65	505.91	25.06	100.81	100.32	29.01	50.25	Grün
[Tra 8] Tra 8	506.02	50.60	505.40	25.04	100.76	100.27	29.00	50.22	Grün
[Tra 9] Tra 9	506.12	50.61	505.50	25.04	100.77	100.28	29.00	50.23	Grün
[Tra 10] Tra 10	505.72	50.57	505.10	25.02	100.73	100.24	28.99	50.21	Grün
[Tra 11] Tra 11	505.57	50.56	504.95	25.01	100.71	100.23	28.98	50.20	Grün

Name	IL1(A) [A]	IL2(A) [A]	IL3(A) [A]	IL1(B) [A]	IL2(B) [A]	IL3(B) [A]	Ir(A) [A]	Ir(B) [A]	Zustand
[Tra 1] 40MVA	28.39	28.39	28.39	156.17	156.17	156.17	209.95	1154.70	Grün
[Tra 2] Tra 2	8.37	8.37	8.37	724.51	724.51	724.51	28.87	1443.38	Grün
[Tra 3] Tra 3	8.36	8.36	8.36	724.33	724.33	724.33	28.87	1443.38	Grün
[Tra 4] Tra 4	8.36	8.36	8.36	724.33	724.33	724.33	28.87	1443.38	Grün
[Tra 5] Tra 5	8.37	8.37	8.37	724.69	724.69	724.69	28.87	1443.38	Grün
[Tra 6] Tra 6	8.37	8.37	8.37	724.80	724.80	724.80	28.87	1443.38	Grün
[Tra 7] Tra 7	8.37	8.37	8.37	725.26	725.26	725.26	28.87	1443.38	Grün
[Tra 8] Tra 8	8.37	8.37	8.37	724.90	724.90	724.90	28.87	1443.38	Grün
[Tra 9] Tra 9	8.37	8.37	8.37	724.97	724.97	724.97	28.87	1443.38	Grün
[Tra 10] Tra 10	8.37	8.37	8.37	724.68	724.68	724.68	28.87	1443.38	Grün
[Tra 11] Tra 11	8.37	8.37	8.37	724.57	724.57	724.57	28.87	1443.38	Grün

Name	Position Stufenschalter	dUges [%Ur] Wicklung A	dUges [%Ur] Wicklung B	dU [%Ur] pro Stufe
[Tra 1] 40MVA	Spannungsregler ausgeschaltet	---	---	---
[Tra 2] Tra 2	Spannungsregler ausgeschaltet	---	---	---
[Tra 3] Tra 3	Spannungsregler ausgeschaltet	---	---	---
[Tra 4] Tra 4	Spannungsregler ausgeschaltet	---	---	---
[Tra 5] Tra 5	Spannungsregler ausgeschaltet	---	---	---
[Tra 6] Tra 6	Spannungsregler ausgeschaltet	---	---	---
[Tra 7] Tra 7	Spannungsregler ausgeschaltet	---	---	---
[Tra 8] Tra 8	Spannungsregler ausgeschaltet	---	---	---
[Tra 9] Tra 9	Spannungsregler ausgeschaltet	---	---	---

[Tra 10] Tra 10	Spannungsregler ausgeschaltet	---	---	---
[Tra 11] Tra 11	Spannungsregler ausgeschaltet	---	---	---

Netzzustandsanalyse: Leitungen

Leitung: Bewertung nach	uneingeschränkt zulässig	eingeschränkt zulässig	unzulässig
VDE 0276	14	---	0
BDEW Ampelkonzept	14	0	0
EN 50160	14	---	0

Name	HB [%]	ILmax [%]	Umax [%]	Umin [%]	Zustand
[Line 4] L1: 5km	0.000	12.915	100.815	100.726	Grün
[Line 5] L2: 2km	0.000	7.903	100.726	100.711	Grün
[Line 6] L6: 0.5km	0.000	2.481	100.726	100.723	Grün
[Line 7] L3: 7km	0.000	2.717	100.711	100.676	Grün
[Line 8] L4: 5km	0.000	2.917	100.711	100.703	Grün
[Line 9] L5: 4km	0.000	2.504	100.703	100.676	Grün
[Line 10] L8: 5km	0.000	6.006	100.815	100.755	Grün
[Line 11] L7: 3km	0.000	2.461	100.724	100.702	Grün
[Line 12] L10: 2km	0.000	3.444	100.756	100.742	Grün
[Line 13] L9: 7km	0.000	4.336	100.815	100.766	Grün
[Line 14] L11: 5km	0.000	1.624	100.766	100.742	Grün
[Line 15] L12: 2km	0.000	2.432	100.742	100.726	Grün
[Line 16] L14: 5km	0.000	1.517	100.815	100.806	Grün
[Line 17] L13: 5km	0.000	1.517	100.815	100.806	Grün

Häufigkeiten des Handlungsbedarfes (HB) der Leitungen

Handlungsbedarf HB [%]	Anzahl Leitungen
=0%	14
]0% - 10%]	0
]10% - 20%]	0
]20% - 30%]	0
]30% - 40%]	0
]40% - 50%]	0
]50% - 60%]	0
]60% - 70%]	0
]70% - 80%]	0
]80% - 90%]	0
]90% - 100%]	0
>100%	0

Häufigkeiten der maximalen Auslastung der Leitungen

Maximale Auslastung [%]	Anzahl Leitungen
=0%	0
]0% - 10%]	13
]10% - 20%]	1
]20% - 30%]	0
]30% - 40%]	0
]40% - 50%]	0
]50% - 60%]	0
]60% - 70%]	0
]70% - 80%]	0

]80% - 90%]	0
]90% - 100%]	0
>100%	0

Ergebnisse der Netzzustandsanalyse und Netzzustandsdiagnose

Netzfaktor fN (Leitung) [%]	100
Netzfaktor fN (Sammelschiene) [%]	100
Netzfaktor fN [%]	100

Genauigkeit der Lastflussberechnung

Erzeugungsanlage (DEA): ϕ [°]	0.000
Erzeugungsanlage (DEA): MAX(ϕ) [°]	0.000
Erzeugungsanlage (DEA): S [kVA]	0.000
Erzeugungsanlage (DEA): S [%]	0.000
Erzeugungsanlage (DEA): MAX(S) [%]	0.000
Verbraucherlast, Leitung, Transformator 2-Wicklung: S [%]	0.488
Verbraucherlast, Leitung, Transformator 2-Wicklung: Max(S) [%]	0.643
Netzeinspeisung: P [%]	0.000
Netzeinspeisung: U [%]	0.000